

TSP100 
futurePRNT

Hardware Manual

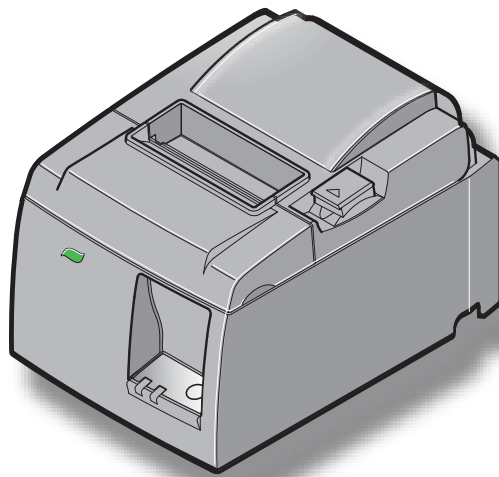

Model: TSP143IIU

**Federal Communications Commission
Radio Frequency Interference
Statement**

This device complies with Part 15 of the FCC Rules. Operation is subject to the following two conditions: (1) This device may not cause harmful interference, and (2) this device must accept any interference received, including interference that may cause undesired operation.

NOTE: This equipment has been tested and found to comply with the limits for a Class A digital device, pursuant to Part 15 of the FCC Rules. These limits are designed to provide reasonable protection against harmful interference when the equipment is operated in a commercial environment. This equipment generates, uses and can radiate radio frequency energy and, if not installed and used in accordance with the instruction manual, may cause harmful interference to radio communications. Operation of this equipment in a residential area is likely to cause harmful interference in which case the user will be required to correct the interference at his own expense.

This statement will be applied only for the printers marketed in U.S.A.

FCC WARNING

Changes or modifications not expressly approved by the party responsible for compliance could void the user's authority to operate the equipment.

For compliance with the Federal Noise Interference Standard, this equipment requires a shielded cable.

For RF interference suppression, if a ferrite core is provided with this device, affix it to the interface cable

**Statement of
The Canadian Department of Communications
Radio Interference Regulationst**

This Class A digital apparatus complies with Canadian ICES-003.

Cet appareil numérique de la classe A est conforme à la norme NMB-003 du Canada.

The above statement applies only to printers marketed in Canada.

Trademark acknowledgments

TSP100II: Star Micronics Co., Ltd.

Notice

- All rights reserved. Reproduction of any part of this manual in any form whatsoever, without STAR's express permission is forbidden.
- The contents of this manual are subject to change without notice.
- All efforts have been made to ensure the accuracy of the contents of this manual at the time of going to press. However, should any errors be detected, STAR would greatly appreciate being informed of them.
- The above notwithstanding, STAR can assume no responsibility for any errors in this manual.

TABLE OF CONTENTS

1. Unpacking and Installation	1
1-1. Unpacking	1
1-2. Choosing a place for the printer	2
1-3. Nomenclature	3
2. Product Features	4
2-1. Product Features	4
2-2. Operation Modes.....	4
3. Setup	5
3-1. Connecting the Power Cord	5
3-2. Connecting the USB Cable to the Printer.....	6
3-3. Connecting to a Peripheral Unit.....	7
3-4. Turning Power On and Power Off.....	8
3-5. Loading the Paper Roll.....	10
4. Attaching the Accessories	14
4-1. Attaching the Upper Guide.....	14
4-2. Attaching the Holder Plate.....	15
4-3. Attaching the Rubber Feet.....	17
5. Thermal Roll Paper Specification	18
5-1. Roll paper specification	18
5-2. Recommended paper	18
6. Control Panel and Other Functions	19
6-1. Control Panel.....	19
6-2. Lamp Indicator	19
6-3. Self-Printing.....	21
7. Preventing and Clearing Paper Jams	22
7-1. Preventing Paper Jams	22
7-2. Removing Paper Jam.....	22
7-3. Releasing a Locked Cutter	24
8. Periodical Cleaning	26
8-1. Cleaning the Thermal Head	26
8-2. Cleaning the Rubber Roller.....	26
8-3. Cleaning the Paper Holder and the Surrounding Area.....	26
9. Peripheral Unit Drive Circuit	27
10. Specifications	29
10-1. General Specifications	29
10-2. Auto Cutter Specifications.....	30
10-3. Interface	30
10-4. Electrical Characteristics	30
10-5. Environmental Requirements	31
10-6. Reliability	32

Please access the following URL
<http://www.star-m.jp/eng/dl/dl02.htm>
for the latest revision of the manual.

1. Unpacking and Installation

1-1. Unpacking

After unpacking the unit, check that all the necessary accessories are included in the package.

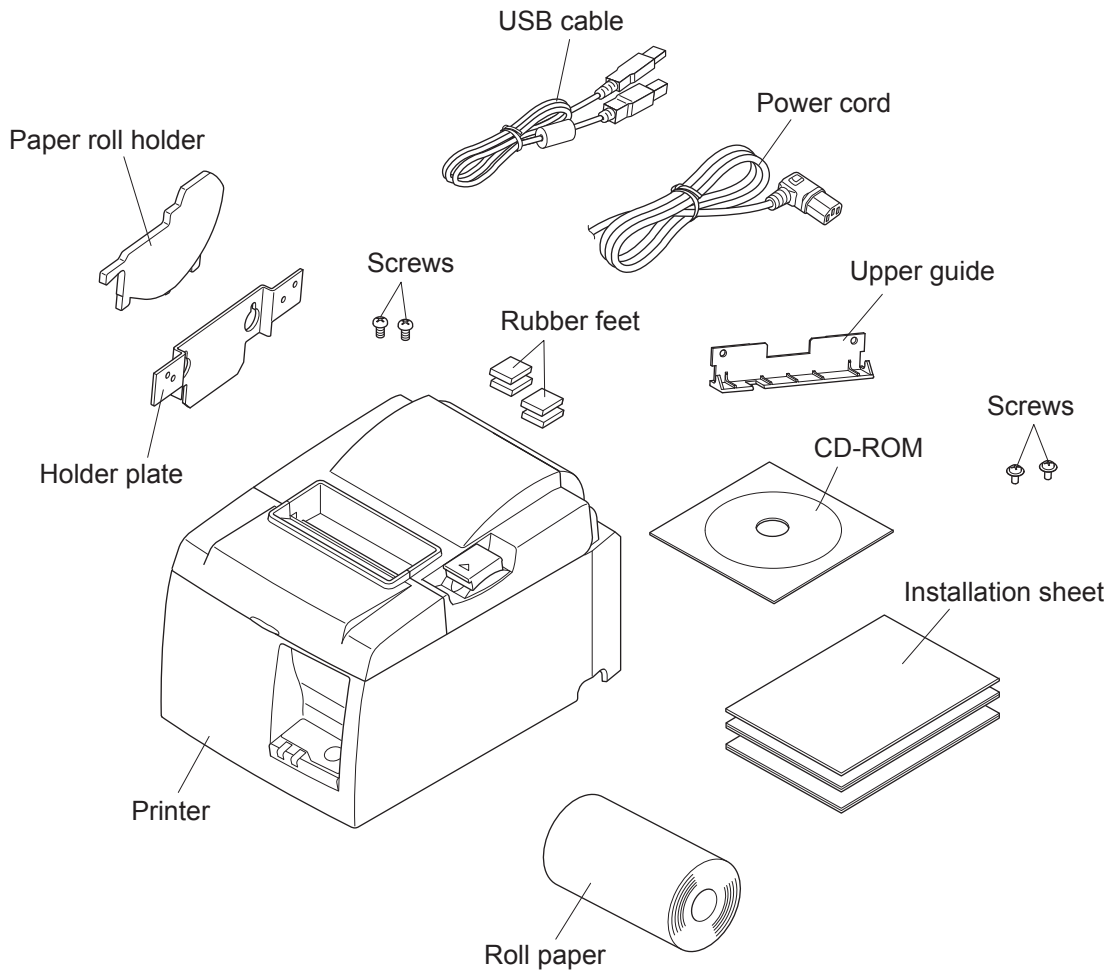

Fig. 1-1 Unpacking

If anything is missing, contact the dealer where you bought the printer and ask them to supply the missing part. Note that it is a good idea to keep the original box and all the packing materials just in case you need to pack the printer up again and send it somewhere at a later date.

1-2. Choosing a place for the printer

Before actually unpacking the printer, you should take a few minutes to think about where you plan to use it. Remember the following points when doing this.

- ✓ Choose a firm, level surface where the printer will not be exposed to vibration.
- ✓ The power outlet you plan to connect to for power should be nearby and unobstructed.
- ✓ Make sure that the printer is close enough to your host computer for you to connect the two.
- ✓ Make sure that the printer is not exposed to direct sunlight.
- ✓ Make sure that the printer is well away from heaters and other sources of extreme heat.
- ✓ Make sure that the surrounding area is clean, dry, and free of dust.
- ✓ Make sure that the printer is connected to a reliable power outlet. It should not be on the same electric circuit as copiers, refrigerators, or other appliances that cause power spikes.
- ✓ Make sure that the room where you are using the printer is not too humid.
- ✓ When disposing of the printer, obey local regulations.
- ✓ This device employs a DC motor and switches that have an electrical contact point. Avoid using the device in environments where silicon gas can become volatile.

⚠ WARNING

- ✓ Shut down your equipment immediately if it produces smoke, a strange odor, or unusual noise. Immediately unplug the equipment and contact your dealer for advice.
- ✓ Never attempt to repair this product yourself. Improper repair work can be dangerous.
- ✓ Never disassemble or modify this product. Tampering with this product may result in injury, fire, or electric shock.

1-3. Nomenclature

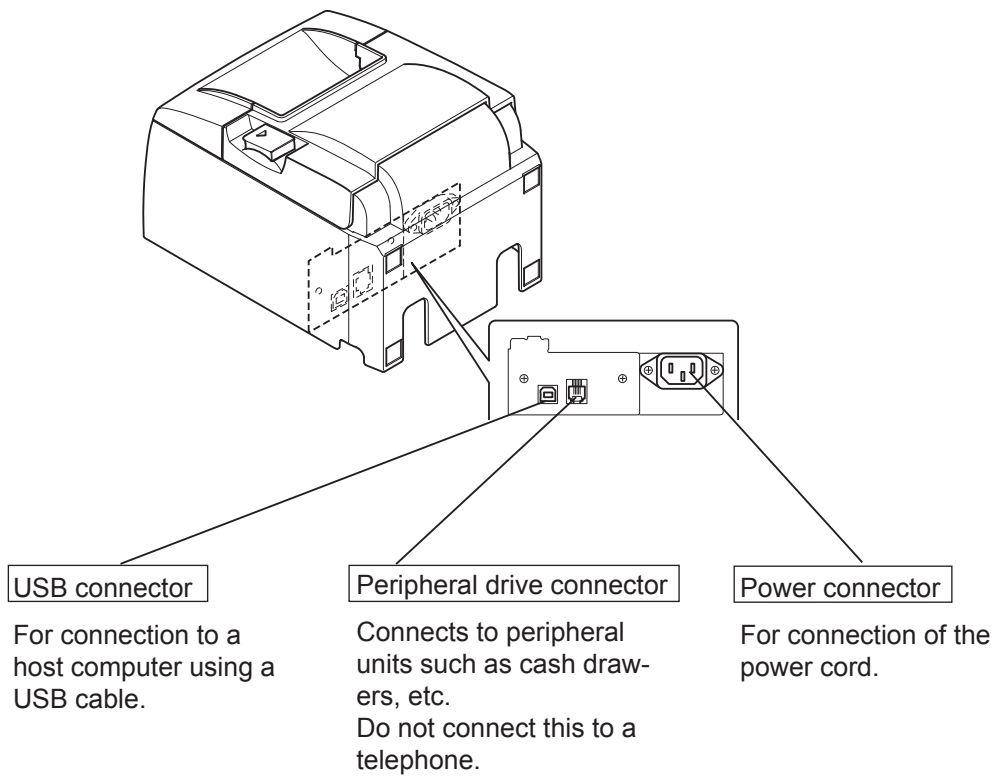
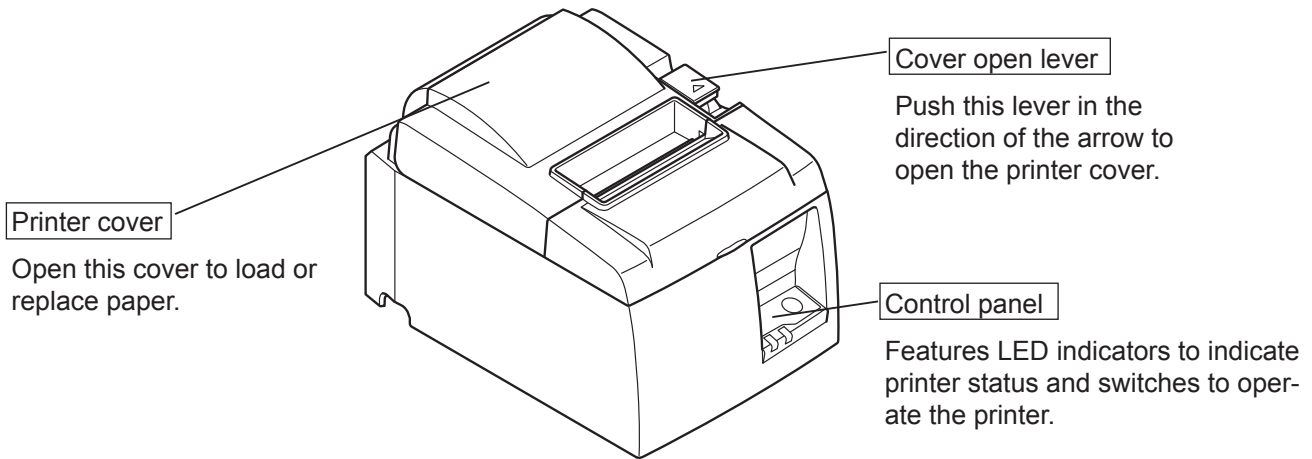

2. Product Features

2-1. Product Features

- This printer is not equipped with a power switch. The printer turns on when the computer, which the printer is connected to, is turned on.
- After the paper is discharged, the roll paper is rewound to reduce the margin on the leading edge of the paper, which reduces the amount of paper used.
- The amount of paper used is reduced using small printing.
- When the computer enters stand-by or hibernates, the printer automatically enters the print ready mode or system off mode to reduce power consumption.
- When the printer is not printing, the printer automatically enters the print ready mode to reduce power consumption while it is waiting for the next print job.
(However, depending on the computer configuration and connection environment, the above function may not operate.)

2-2. Operation Modes

• System Off Mode

When the computer is turned off, the printer turns off.

In addition, the printer enters the system off mode when the computer enters stand by or hibernates. (However, the printer continues to receive a very small amount of electricity from the power source in this case.)

• Print Ready Mode

When the printer is not printing, the printer automatically enters the print ready mode to reduce power consumption.

• Printing

The printer is printing (including when the roll paper is being fed)

3. Setup

3-1. Connecting the Power Cord

- (1) Check the label on the back or bottom of the printer to make sure its voltage matches that of the AC outlet. Also make sure the plug on the power cord matches the AC outlet.
- (2) If the power cord is not attached to the printer, plug the appropriate end into the AC inlet on the back of the printer.
- (3) Plug the power cord into a properly grounded AC outlet.

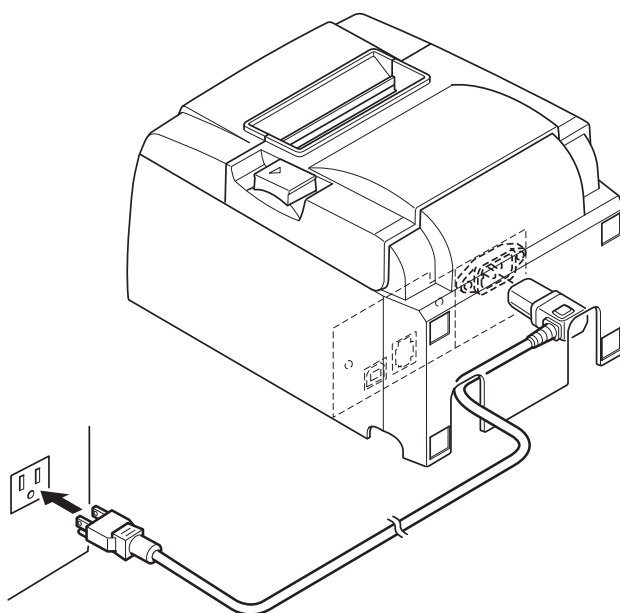

⚠ CAUTION

If the voltage shown on the label on the bottom of your printer does not match the voltage for your area, contact your dealer immediately.

We recommend that you unplug the printer from the power outlet whenever you do not plan to use it for long periods. Because of this, you should locate the printer so that the power outlet it is plugged into is nearby and easy to access.

3-2. Connecting the USB Cable to the Printer

Pass the cable through the cable support as shown. Then, connect the USB interface cable to the printer.

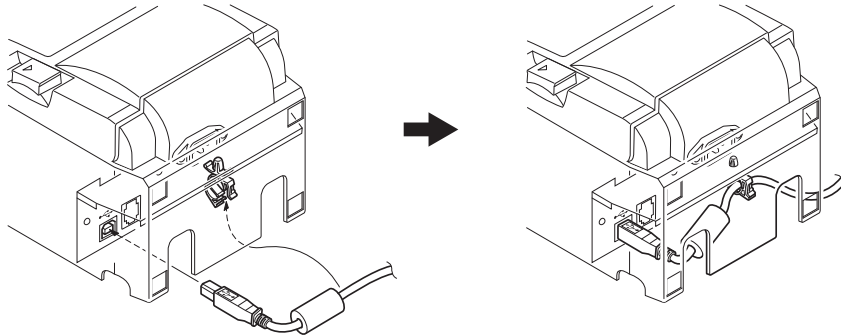

⚠ Precautions regarding USB connections

- 1) Depending on the settings and configurations, the printer may not operate correctly with some computers even if they meet the conditions for the connection environment. In addition, operation is not guaranteed for connections through a USB hub or USB extension board, or for home-built or modified computers.
 - 2) Connect the USB cable directly to the computer's USB port. If the printer is connected through a USB hub or other device, the printer may not operate correctly.
 - 3) This printer requires an electrical current of 100 mA/USB port or more for a given length of time during operations, such as startup. If the electrical current is less than 100 mA, the following devices may malfunction.
 - This printer
 - Devices connected to the computer's other USB ports
-

3-3. Connecting to a Peripheral Unit

You can connect a peripheral unit to the printer using a modular plug. The following describes how to install the ferrite core and make the actual connection. See “Modular plug” on page 28 for details about the type of modular plug that is required. Note that this printer does not come with a modular plug or wire, so it is up to you to obtain one that suits your needs.

⚠ CAUTION

Make sure that the printer is turned off and unplugged from the AC outlet and that the computer is turned off before making connections.

- (1) Connect the peripheral drive cable to the connector on the rear panel of the printer.

⚠ CAUTION

Do not connect a telephone line into the peripheral drive connector. Failure to observe this may result in damage to the printer.

Also, for safety purposes, do not connect wiring to the external drive connector if there is a chance it may carry peripheral voltage.

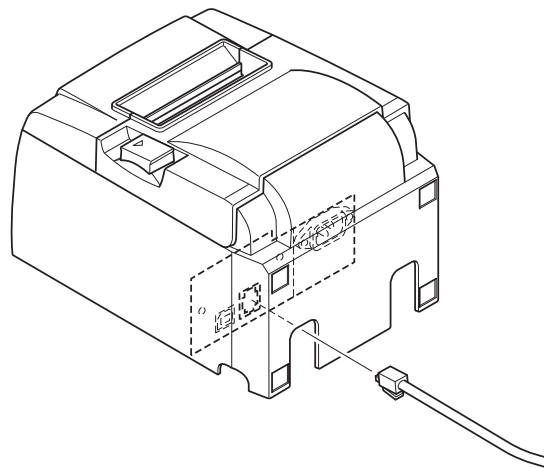

3-4. Turning Power On and Power Off

Important:

This printer is not equipped with a power switch.

- 1) To turn on the printer, the following three conditions must be met.
 - The computer is turned on.
 - The printer's power cord is plugged into an AC outlet.
 - The printer is connected to a computer using the USB cable.
- 2) If the printer is malfunctioning, unplug the power cord and disconnect the USB cable to turn off the printer.

3-4-1. Turning Power On (Print Ready Mode)

There are two ways to turn on the power.

1) Turning power on manually

Make sure that the printer's power cord is plugged into an AC outlet.

Connect the USB cable to the USB port of a computer that is turned on. When the USB cable is connected, the printer turns on and the POWER lamp on the control panel lights up.

2) Turning power on automatically

Make sure that the printer's power cord is plugged into an AC outlet.

Make sure that the USB cable is connected to the USB port of a computer that is turned off. When the computer is turned on, the printer turns on and the POWER lamp on the control panel lights up.

3-4-2. Turning Power Off (System Off Mode)

There are two ways to turn off the power.

1) Turning power off manually

Unplug the power cord and disconnect the USB cable.

2) Turning power off automatically

Turn off the computer. The printer also turns off when the computer enters stand-by or hibernates. However, the printer continues to receive a very small amount of electricity from the power. To completely turn off the printer, unplug the power cord and disconnect the USB cable.

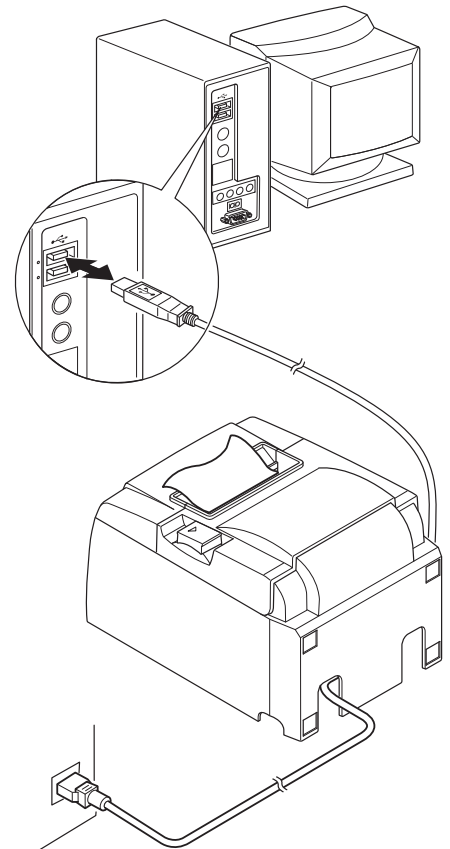

⚠ CAUTION

- *Depending on the computer that is connected to the printer, the printer may not enter the system off mode even if the computer is turned off. To completely turn off the printer, unplug the power cord and disconnect the USB cable.*
 - *Depending on the type of hub used, the printer may not enter the system off mode even if the computer is turned off. To completely turn off the printer, unplug the power cord and disconnect the USB cable.*
-

⚠ Precautions regarding USB connections

- 1) *Depending on the settings and configurations, the printer may not operate correctly with some computers even if they meet the conditions for the connection environment. In addition, operation is not guaranteed for connections through a USB hub or USB extension board, or for home-built or modified computers.*
 - 2) *Connect the USB cable directly to the computer's USB port. If the printer is connected through a USB hub or other device, the printer may not operate correctly.*
 - 3) *This printer requires an electrical current of 100 mA/USB port or more for a given length of time during operations, such as startup. If the electrical current is less than 100 mA, the following devices may malfunction.*
 - *This printer*
 - *Devices connected to the computer's other USB ports*
-

3-5. Loading the Paper Roll

3-5-1. Using 79.5 mm Width Paper Roll

Be sure to use roll paper that matches the printer's specification.

When using a paper roll with an 57.5 mm width, install the paper roll holder as described on the following page.

- 1) Push the cover open lever, and open the printer cover.
- 2) While observing the direction of the roll, set the paper roll into the hollow, and pull on the leading edge of the paper toward you.

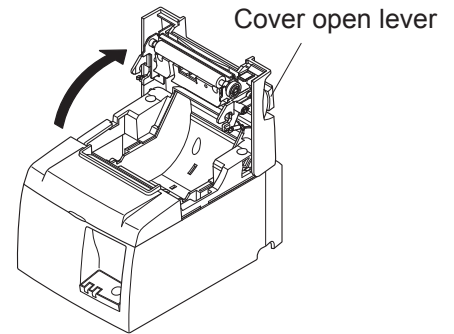

⚠ CAUTION

Do not pull out the end of the paper diagonally, as it will cause the paper to become jammed or skewed.

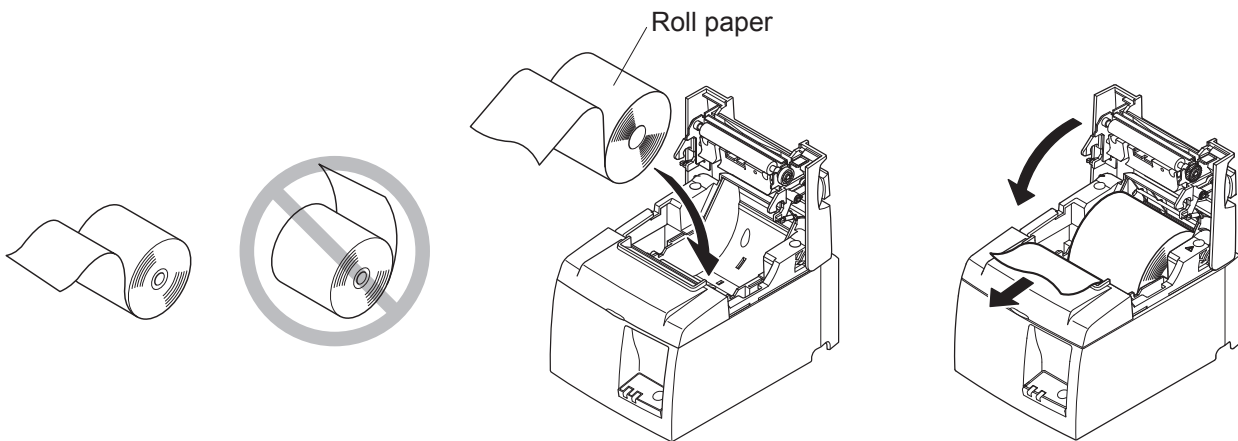

- 3) Push down both sides of the printer cover to close.
Note: Make sure that the printer cover is securely closed.
- 4) If the printer cover is closed after turning on the power, the cutter operates automatically and the front end of the paper is cut.

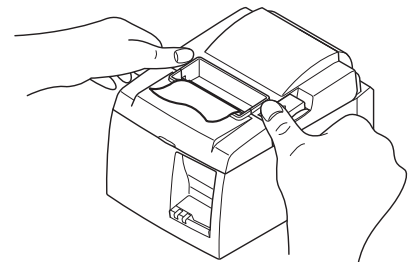

3-5-2. Using 57.5 mm Width Paper Roll

When using a paper roll with 57.5 mm width, install the supplied paper guide on the printer. To change the effective print width (roll paper width), change the setting of the Print Width in the Configuration. For details on the setting of the Print Width, refer to the software manual located in the “Documents” folders on the CD-ROM.

- ① Insert the paper roll holder into the unit, making sure not to touch the assist roller, and then fit the holder into the slots as shown.

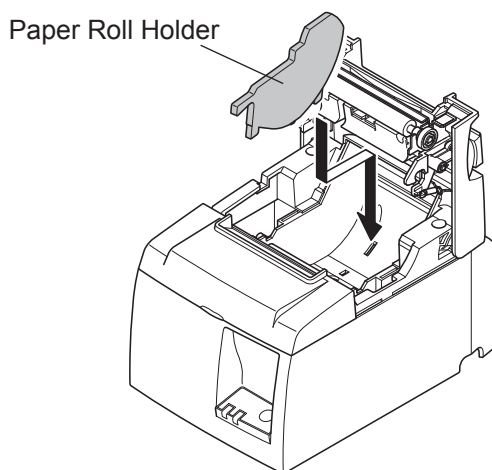

- ② Secure the paper guide by pushing the area marked “A” down until it clicks into place.

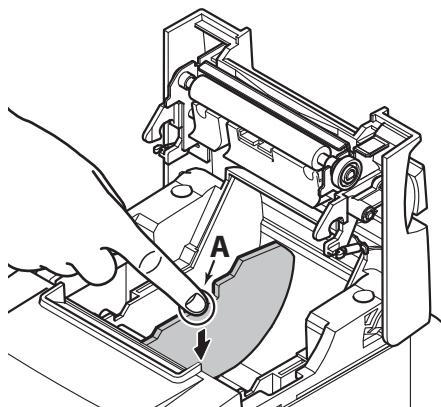

Note: After using a paper roll with a width of 57.5 mm, do not change to a paper roll with a width of 79.5 mm. (This is because the printer head has deteriorated as a result of a portion of the head having been in direct contact with the platen.)

Caution Symbol



These labels are located near the thermal print head.

Because the thermal print head is hot immediately after printing, do not touch it. Static electricity can damage the thermal print head. To protect the thermal print head from static electricity, do not touch it.



This symbol is placed near the cutter.

Never touch the cutter blade, as you could injure your fingers.



This symbol is placed near the peripheral drive connector.

Do not connect this to a telephone.



This symbol label or stamp is placed near the screws securing the case or the protective plate, which should not be opened by individuals other than service personnel. Individuals, other than service personnel, should not remove these screws. High voltage areas in the case can be dangerous.

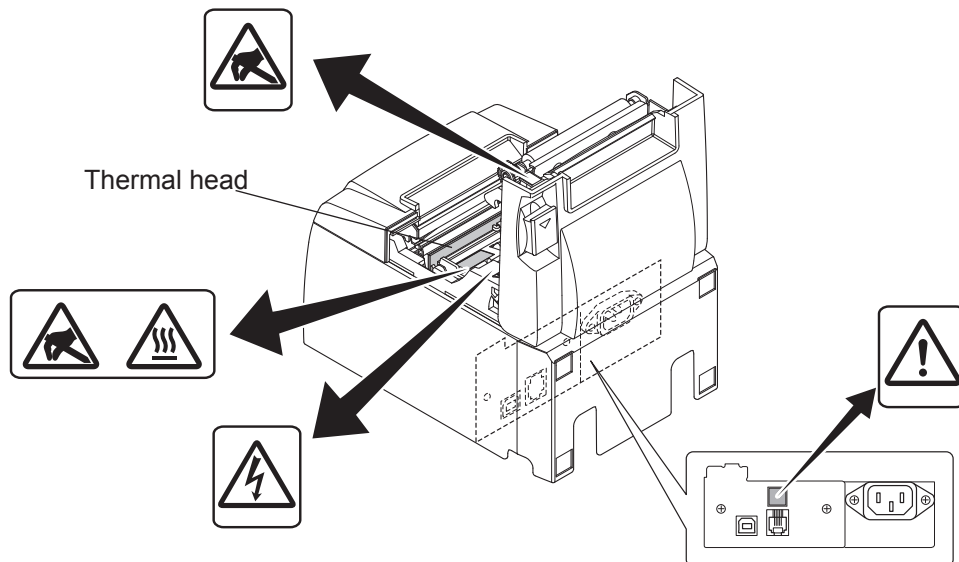

⚠ WARNING

- 1) *Do not touch the cutter blade.*
 - *There is a cutter inside the paper outlet slot. Not only should you not put your hand in the paper outlet slot while printing is in progress, never put your hand into the outlet even when printing is not in progress.*
 - *The printer cover can be opened when replacing the paper. However, since the cutter blade is on the inside of the printer cover, be careful not to place your face or hands too close to the cutter blade.*
 - 2) *During and immediately after printing, the area around the thermal head is very hot. Do not touch it, as you could be burned.*
 - 3) *Unplug the equipment immediately if it produces smoke, a strange odor, or unusual noise and contact your dealer for advice.*
 - 4) *Never attempt to repair this product yourself. Improper repair work can be dangerous.*
 - 5) *Never disassemble or modify this product. Tampering with this product may result in injury, fire, or electric shock.*
-

⚠ CAUTION

- 1) Do not operate the cover open lever while pressing on the printer cover with your hand.
 - 2) Do not push the cover open lever and open the printer cover when printing is in progress or when the auto cutter is operating.
 - 3) Do not push out paper while the printer cover is closed.
 - 4) The heating element and the driver IC of the thermal head are easily damaged. Do not touch them with metal objects, sandpaper, etc.
 - 5) Printing quality may suffer if the thermal head heating element becomes soiled by being touched with your hands. Do not touch the thermal head heating element.
 - 6) There is a risk of damage to the driver IC of the thermal head from static electricity. Never directly touch the IC.
 - 7) The printing quality and working life of the thermal head cannot be guaranteed if any paper other than that recommended is used. In particular, paper containing [Na⁺, K⁺, Cl⁻] may drastically reduce the working life of the thermal head. Please exercise caution.
 - 8) Do not operate the printer if there is moisture on the front surface of the head from condensation, etc.
 - 9) A printed piece of thermal paper may become electrically charged. If the printer is placed vertically or mounted on a wall, the cut piece of paper may stick to the printer, instead of falling. Beware that this could cause a problem if you use a stacker that stores the pieces of paper that fall freely.
 - 10) Do not change the paper width during use. The thermal printing head, rubber roller, and cutter wear differently according to the paper width. This can cause the printing or cutter movement to malfunction.
 - 11) Do not transport the printer with its cover open and holding it by the cover.
 - 12) Do not forcibly pull on the interface cable, power cord, or cash drawer cable that is connected. To detach a connector, make sure to grasp it at the connector portion, without applying excessive stress on the connector at the printer
 - 13) If your printer gets hang-up, you must reset it by plugging out/in the USB cable. However, the intervals of per plugging out/in must be 5 seconds or more. Shorter interval may cause malfunction.
 - 14) Do not turn off the computer or put the computer in stand-by mode during printing.
 - 15) Do not unplug the power cord or disconnect the USB cable during it is working.
-

⚠ Notes on Using the Auto Cutter

- 1) If the cutter is not in its home position after an error, first eliminate the cause of the error; then, turn the power back ON.
 - 2) A margin of 5 mm or more is recommended from the end of the printed area to the cutting position.
 - 3) Do not attempt to remove the paper during a cut, as this can cause a paper jam
-

4. Attaching the Accessories

The following accessories are necessary when mounting the printer to a wall.

- Upper guide and two flanged screws
- Holder plate and two flangeless screws

The following accessories are necessary when positioning the printer vertically.

- Upper guide and two flanged screws
- Four rubber feet

4-1. Attaching the Upper Guide

- 1) Push the cover open lever, and open the printer cover.
- 2) Fit the upper guide onto the shaft until the hooks on the guide click into place.
- 3) Tighten the two screws (M3x6 flanged screws) that were supplied to secure the upper guide in place.

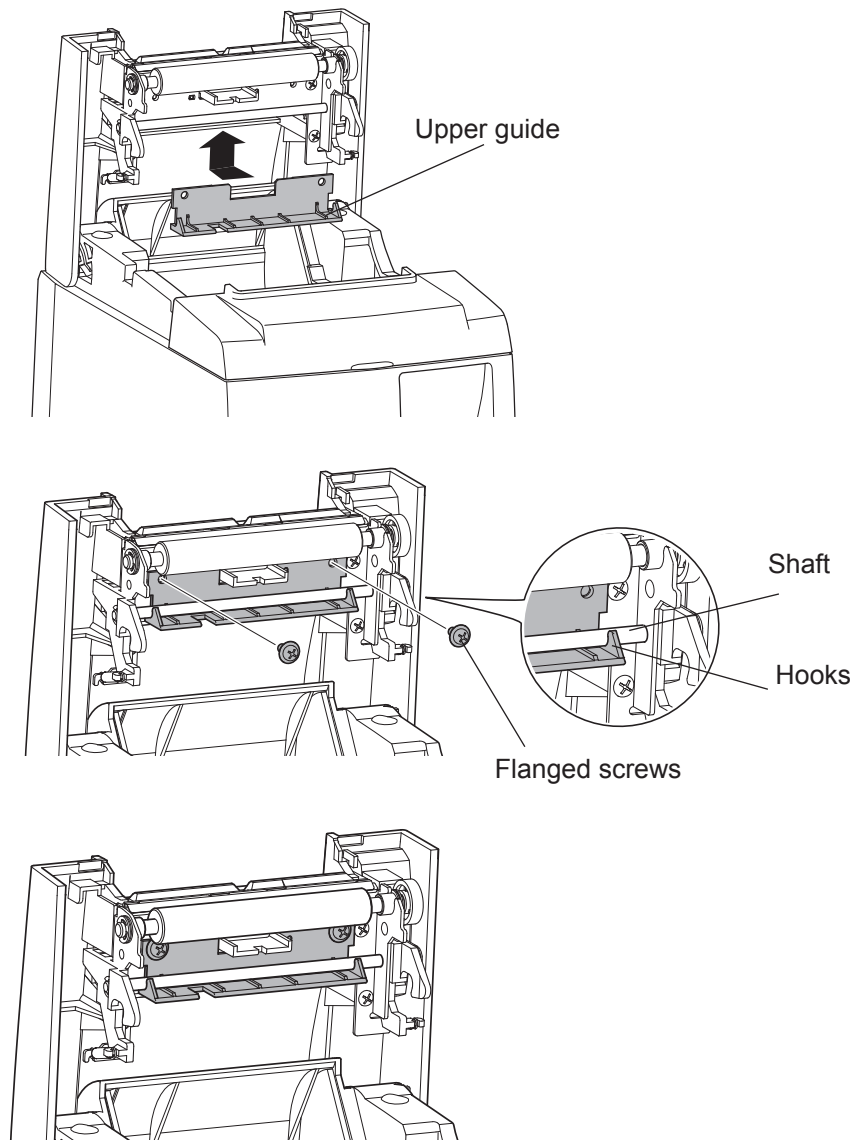

4-2. Attaching the Holder Plate

- The holder plate is attached to the printer using the included screws and is hooked onto screws that are installed into the wall.
- The screws on the wall are not included.
Use commercially available screws (4 mm diameter) that are suitable for the wall material (wood, steel beam, concrete, etc.).
- The printer's weight is approximately 2.4 kg when the largest diameter roll paper is loaded.
Use screws on the wall that have both shear strength and pulling-out strength to withstand a force of at least 12 kgf (118 N).

Precautions regarding installation

⚠ CAUTION

This caution indicates information that, if ignored, could lead to personal injury or property damage.

- *Be sure to have qualified personnel install the specified screws and printer to the wall. Star is not responsible for any accidents or injuries that occur as a result of improper installation, misuse, or modifications.
Especially when installing the printer at a high location, make sure that the printer is securely installed to the wall.
If the printer is not installed securely and falls, personal injury or damage to the printer may result.*
 - *Make sure that the mounting surface and installation screws are strong enough to install the printer.
Securely install the printer so that the weight of the printer and any connected cables will not cause the printer to fall.
Otherwise, personal injury or damage to the printer may result.*
 - *Do not install the printer in an unstable location or a location that is exposed to vibration and shocks.
If the printer falls, personal injury or damage to the printer may result.*
-

- (1) Attach the holding plate to the printer. Then tighten the two screws that were supplied to secure it in place.

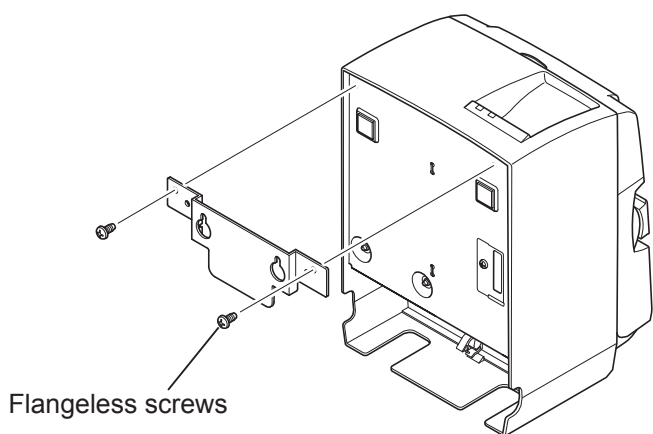

- (2) Position the printer over the screws, etc., on the wall and then slide it downward to set it in place.

After setting the printer in place, check the screws on the wall again to make sure that they are able to support the printer's weight.

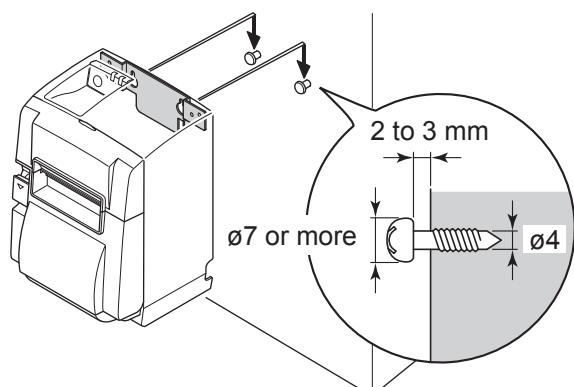

⚠ CAUTION

- The printer's weight is approximately 2.4 kg when the largest diameter roll paper is loaded.
- Use screws on the wall that have both shear strength and pulling-out strength to withstand a force of at least 12 kgf (118 N).

- (3) Push the cover open lever, and open the printer cover.
- (4) Insert the roll paper as shown.

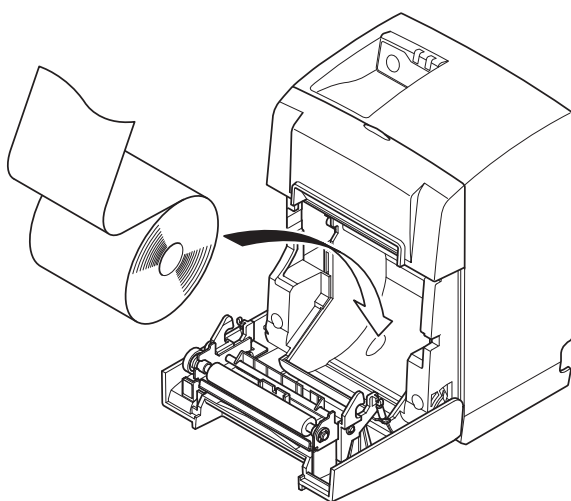

4-3. Attaching the Rubber Feet

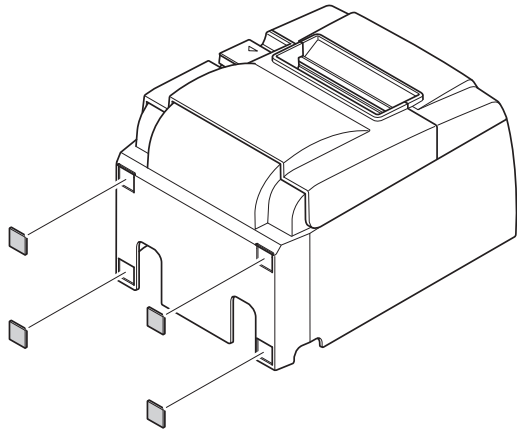

- (1) Attach the four rubber feet in the positions shown in the figure. Ensure that any soiling has been completely wiped off before attaching the rubber feet.

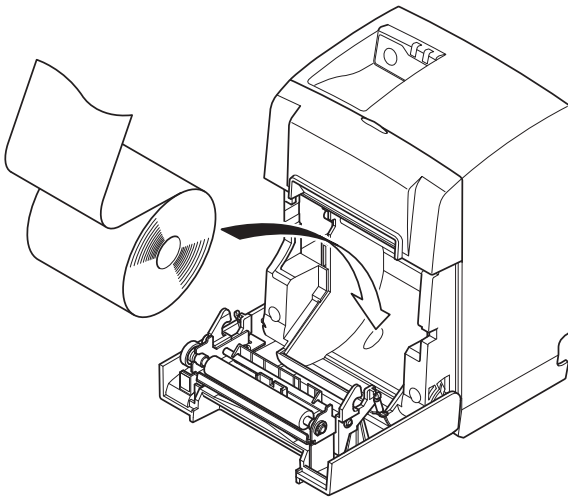

- (2) Push the cover open lever, and open the printer cover.
- (3) Insert the roll paper as shown.

5. Thermal Roll Paper Specification

When consumable parts have run out, use those specified below.

5-1. Roll paper specification

Thermal paper

Thickness: 57~85 μm

Note: When using thin paper with a thickness of less than 65 μm , only the F5041 (Mitsubishi HiTec Paper Flensburg GmbH), TF50KS-E2D (Nippon Paper Industries) and P300/P310 (KSP) paper types are recommended.

Width: 79.5 \pm 0.5 mm (57.5 \pm 0.5 mm when the paper roller holder is used)

Outer roll diameter: ϕ 83 mm or less

Take up paper roll width: 80 $^{+0.5}_{-1}$ mm or (58 $^{+0.5}_{-1}$ mm when the paper roller holder is used)

Core outer/inner diameter

Core outer

ϕ 18 \pm 1 mm

Core inner

ϕ 12 \pm 1 mm

Printed surface: Outer edge of roll

Tail end handling: Do not use paste or glue to secure the roll paper or its core.
Do not fold the tail end of the paper.

5-2. Recommended paper

- Note:**
- 1) The print density may vary depending on the type of roll paper and operating environment.
 - 2) A reader or scanner may not be able to scan a printed bar code or characters depending on the print density. Make sure that your reader or scanner is able to scan correctly beforehand.

Manufacturer	Product name	Quality characteristics/Use	Paper thickness (μm)
Mitsubishi Paper Mills Limited	P220AG	normal type paper	65 (thickness)
	HP220A	high image stability paper	65 (thickness)
	HP220AB-1	high image stability paper	75 (thickness)
Mitsubishi HiTec Paper Flensburg GmbH	F5041	normal type paper	60 (thickness)
Oji Paper Co., Ltd.	PD150R	normal type paper	75 (thickness)
	PD160R	high image stability paper	65/75 (thickness)
	PD450	normal type paper	65 (thickness)
Nippon Paper Industries	TF50KS-E2D	normal type paper	59 (thickness)
	TF60KS-E	normal type paper	75 (thickness)
Kanzaki Specialty Papers Inc. (KSP)	P320RB	2 color paper: Red & Black	65 (thickness)
	P320BB	2 color paper: Blue & Black	65 (thickness)
	P300/P310	normal type paper	57/58 (thickness)

Note: The P300/P310 (KSP) paper types cannot be used when the printer is positioned vertically.

Note:

Access the following URL for the information of the recommended paper.

<http://www.star-m.jp/eng/dl/dl02.htm>

6. Control Panel and Other Functions

6-1. Control Panel

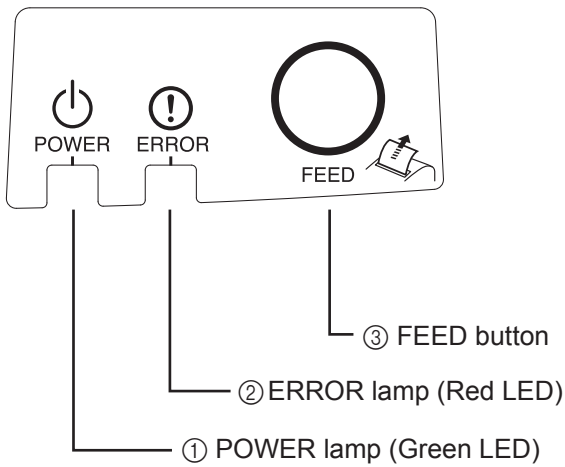

- ① POWER lamp (Green LED)
Lights when the power is ON.

Important:

This printer is not equipped with a power switch. After plugging the power cord into an AC outlet, the printer power will be turned on for the first time when the USB cable is connected to a computer that is turned on.

- ② ERROR lamp (Red LED)
Indicates various errors in combination with POWER lamp.
- ③ FEED button
Press the FEED button to feed roll paper.

6-2. Lamp Indicator

1) Printer Status

Status	POWER Lamp	ERROR Lamp
Printing	On	Off
Print Ready	On	Off
System Off	Off	Off
Errors	Refer to next page.	Refer to next page.

Note: Depending on the USB port used, it may take a short time for the printer to enter the system off mode after the computer is turned off.

2) Automatically recoverable errors

Error Description	POWER Lamp	ERROR Lamp	Recovery Conditions
Cover open error	On	On	Automatically recovered after the printer cover is closed.
Power cord disconnection error	Flashes at 0.5-second intervals *1	Flashes at 0.5-second intervals *1	Automatically recovered after the power cord is plugged into an AC outlet.
Head high temperature detection	Flashes at 0.5-second intervals	Off	Automatically recovered after the print head has cooled.
Board high temperature detection	Flashes at 2-second intervals	Off	Automatically recovered after the printer cover is closed.

*1: The POWER and ERROR lamps blink alternately. If the VM and VCC voltage errors occurred simultaneously, the power cord disconnection error will be displayed even though the cable is connected to an outlet. In such cases, disconnect the power cord from the outlet, then reconnect it. Then connect the USB cable to the PC when it power.

3) Non-recoverable errors

Error Description	POWER Lamp	ERROR Lamp	Recovery Conditions
Head thermistor error	Flashes at 0.5-second intervals	Flashes at 0.5-second intervals	Non-recoverable
Board thermistor error	Flashes at 2-second intervals	Flashes at 2-second intervals	Non-recoverable
VM voltage error	Off	Flashes at 1-second intervals	Non-recoverable
VCC voltage error	Flashes at 1-second intervals	Flashes at 1-second intervals	Non-recoverable
Nonvolatile memory error	Flashes at 0.25-second intervals	Flashes at 0.25-second intervals	Non-recoverable
USB error	Flashes at 5-second intervals	Flashes at 5-second intervals	Non-recoverable
CPU error	Off	Off	Non-recoverable
RAM error	Off	On	Non-recoverable

Note: 1) If a non-recoverable error occurs, turn the power OFF immediately.

2) If a non-recoverable error occurs, please consult the dealer for repairs.

4) Paper cut error

Error Description	POWER Lamp	ERROR Lamp	Recovery Conditions
Paper cut error	Off	Flashes at 0.125-second intervals	For firmware version 1.1 or later: Open the printer cover. Remove the cause (jammed paper) of the error, and close the printer cover. Then, the printer will be recovered. For firmware version 1.0 or if the printer cover cannot be opened because of the cutter lock: Follow the steps described in section 7-3.

Note: If the cutter does not return to its home position or does not perform the initial movement, it will result in a non-recoverable error.

5) Paper out error

Error Description	POWER Lamp	ERROR Lamp	Recovery Conditions
Paper out error	On	Flashes at 0.5-second intervals	Automatically recovered by loading a new paper roll, then closing the printer cover.

6-3. Self-Printing

Test Printing

- 1) Make sure that the computer is turned on.
- 2) Make sure that the printer's power cord is plugged into an AC outlet.
- 3) While holding the FEED button down, connect the USB cable to the computer.

Test printing starts. The version number and printer settings are printed.
After the printer starts printing, release your hand from the FEED button.
After self-printing is completed, the printer will start in the normal mode.

```
*** TSP100IIU Ver1.0
Unit   : Cutter
      FEDCBA9876543210
<2> 00000000000000000000
<4> 00000000000000000000
<C> 00000000000000000000
USB-ID : Disable
Class  : Printer
Cutter : Enable
```

7. Preventing and Clearing Paper Jams

7-1. Preventing Paper Jams

The paper should not be touched during ejection and before it is cut.

Pressing or pulling the paper during ejection may cause a paper jam, paper cutting failure or line feed failure.

7-2. Removing Paper Jam

If a paper jam occurs, clear it as described below.

- (1) Unplug the power cord and disconnect the USB cable.
- (2) Push the lever toward you to open the printer cover.
- (3) Remove the jammed paper.

Note: To prevent parts such as the thermal head or the rubber roller from damage or deformation, do not forcibly pull on the paper with the printer cover closed.

- (4) Position the paper roll straight and close the printer cover gently.

Note 1: Make sure that the paper is positioned straight. If the printer cover is closed with the paper skewed, a paper jam may result.

Note 2: Lock the printer cover by pressing down on the sides. Do not try to close it by pressing down on the centre. The cover may not lock properly.

- (5) Plug the power cord into the AC outlet and connect the USB cable to the computer that is turned on. Then make sure that the ERROR LED is not lit.

Note: While the ERROR LED is lit, the printer will not accept any commands such as the print command, so make sure that the printer cover is locked properly.

Caution Symbol



These labels are located near the thermal print head. Because the thermal print head is hot immediately after printing, do not touch it. Static electricity can damage the thermal print head. To protect the thermal print head from static electricity, do not touch it.



This symbol is placed near the cutter. Never touch the cutter blade, as you could injure your fingers.



This symbol is placed near the peripheral drive connector. Do not connect this to a telephone.



This symbol label or stamp is placed near the screws securing the case or the protective plate, which should not be opened by individuals other than service personnel. Individuals, other than service personnel, should not remove these screws. High voltage areas in the case can be dangerous.

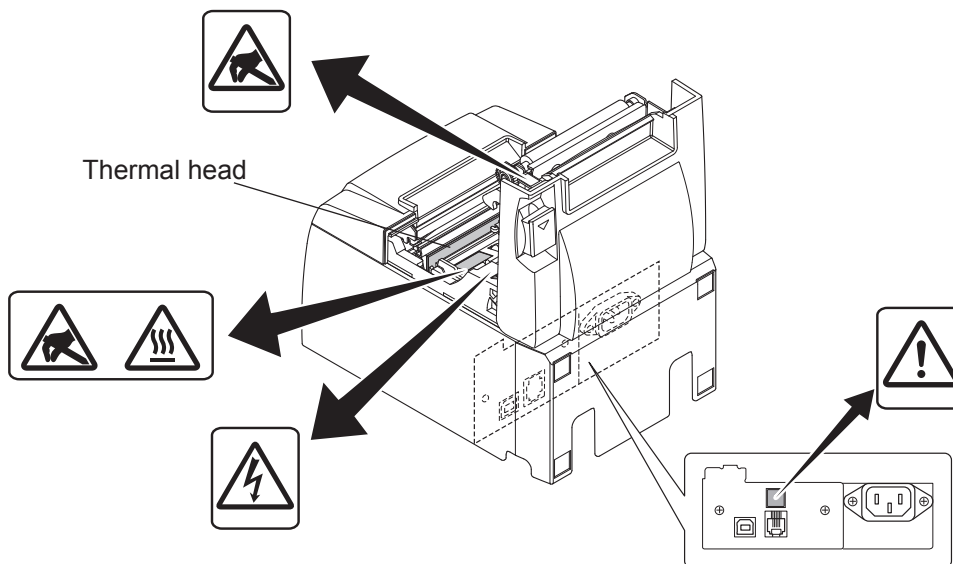

7-3. Releasing a Locked Cutter

If the auto cutter locks up, disconnect the USB cable, and unplug the power cord to turn the printer off. Then reconnect the USB cable, and plug in the power cord to turn the printer on. If restarting the printer does not release the locked cutter, follow the steps below.

⚠ WARNING

Since working on the cutter may be dangerous, be sure to turn off the printer first.

- (1) Unplug the power cord and disconnect the USB cable.
- (2) Remove the front cover to reveal the auto cutter.

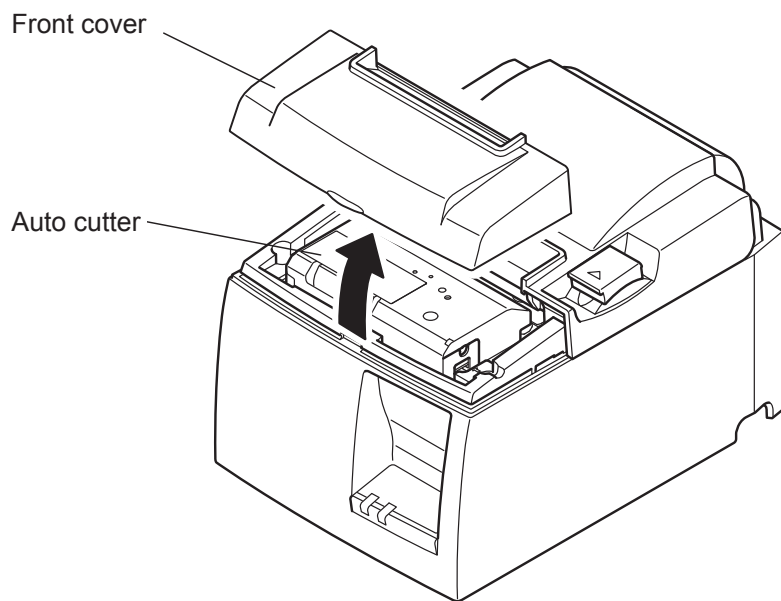

- (3) Remove any jammed paper.

CAUTION: Be careful not to damage the printer while removing any jammed paper. Since the thermal print head is particularly sensitive, be sure not to touch it.

- (4) Insert a Philips screwdriver into the manual operation hole on the side of the cutter, and turn it in the direction of the arrow shown on the right until the rear cover is opened.

CAUTION: If the printer cover does not open easily, do not force the printer cover open. Consult the dealer for repairs.

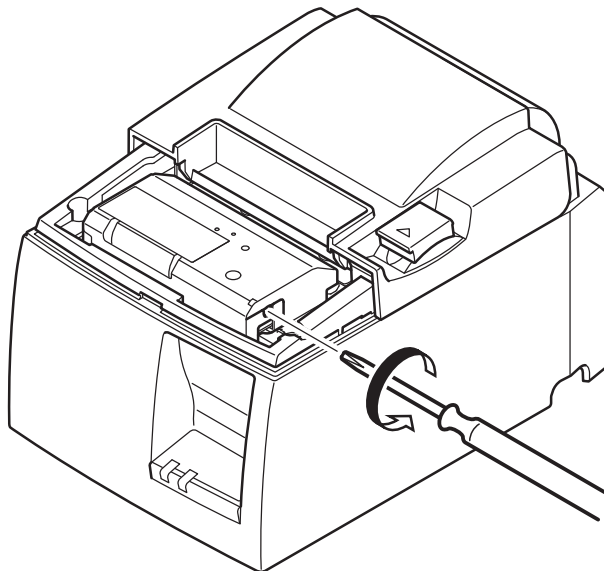

- (5) Open the printer cover, remove any jammed paper, and then reinstall the paper roll.
- (6) Install the front cover.

8. Periodical Cleaning

Printed characters may become partially unclear due to accumulated paper dust and dirt. To prevent such a problem, paper dust collected in the paper holder and paper transport section and on the surface of the thermal head must be removed periodically.

Such cleaning is recommended to be carried out once six month or one million lines.

8-1. Cleaning the Thermal Head

To remove the dark paper dust that has accumulated on the thermal head surface, wipe it clean with cotton swab (or soft cloth) dipped in alcohol (ethanol, methanol, or isopropyl alcohol).

Note 1: The thermal head is easily damaged, so clean it with a soft cloth, taking care not to scratch it.

Note 2: Do not attempt to clean the thermal head immediately after printing, when the thermal head is hot.

Note 3: Beware of the risk of damaging the thermal head as a result of static electricity that may be created during cleaning.

Note 4: Turn the power ON only after the alcohol has dried completely.

8-2. Cleaning the Rubber Roller

Use a dry, soft cloth to wipe off the dust that may have accumulated on the rubber roller. Rotate the platen to clean the entire surface.

8-3. Cleaning the Paper Holder and the Surrounding Area

Clean the paper holder of debris, dust, paper particles, glue, etc. that may have accumulated.

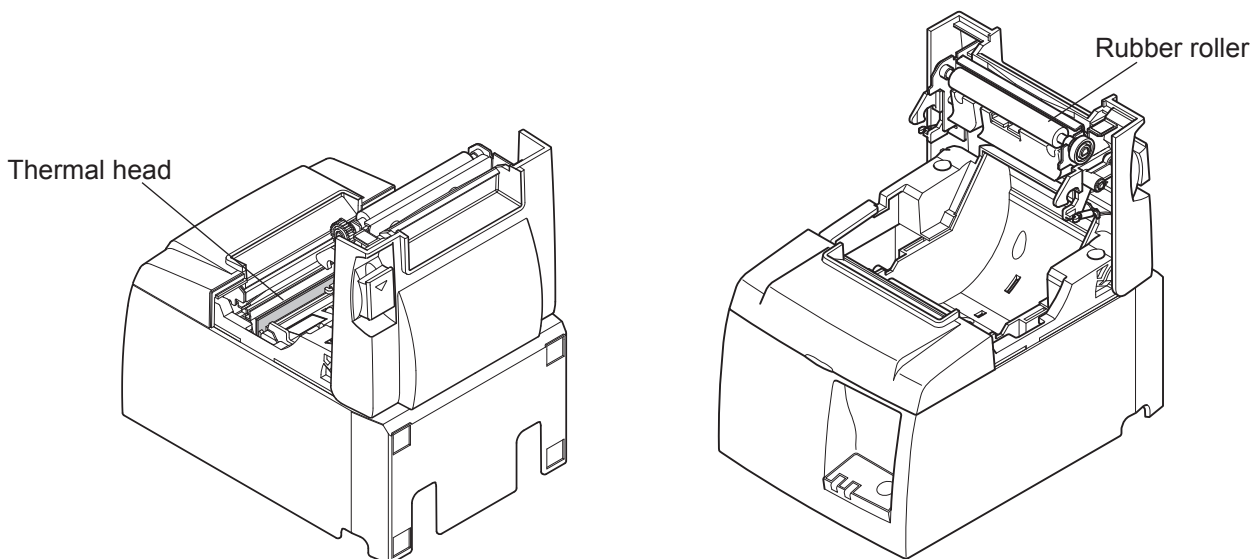

9. Peripheral Unit Drive Circuit

Peripheral unit drive circuit connector only connects to peripheral units such as cash drawers, etc. Do not connect it to a telephone.

Use cables which meet the following specifications.

Peripheral Drive Connector

Pin No.	Signal name	Function	I/O direction
1	FG	Frame ground	—
2	DRD1	Drive signal 1	OUT
3	+24 V	Drive power	OUT
4	+24 V	Drive power	OUT
5	DRD2	Drive signal 2	OUT
6	DRSNS	Sense signal	IN

Modular plug

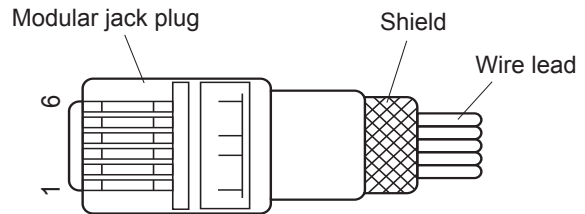

Manufacturer	Model
MOLEX	90075-0007
AMP	641337
FCI	B-66-4

Note: Connect a shielded wire to pin 1 (frame ground).

Drive circuit

The recommended drive unit is shown below.

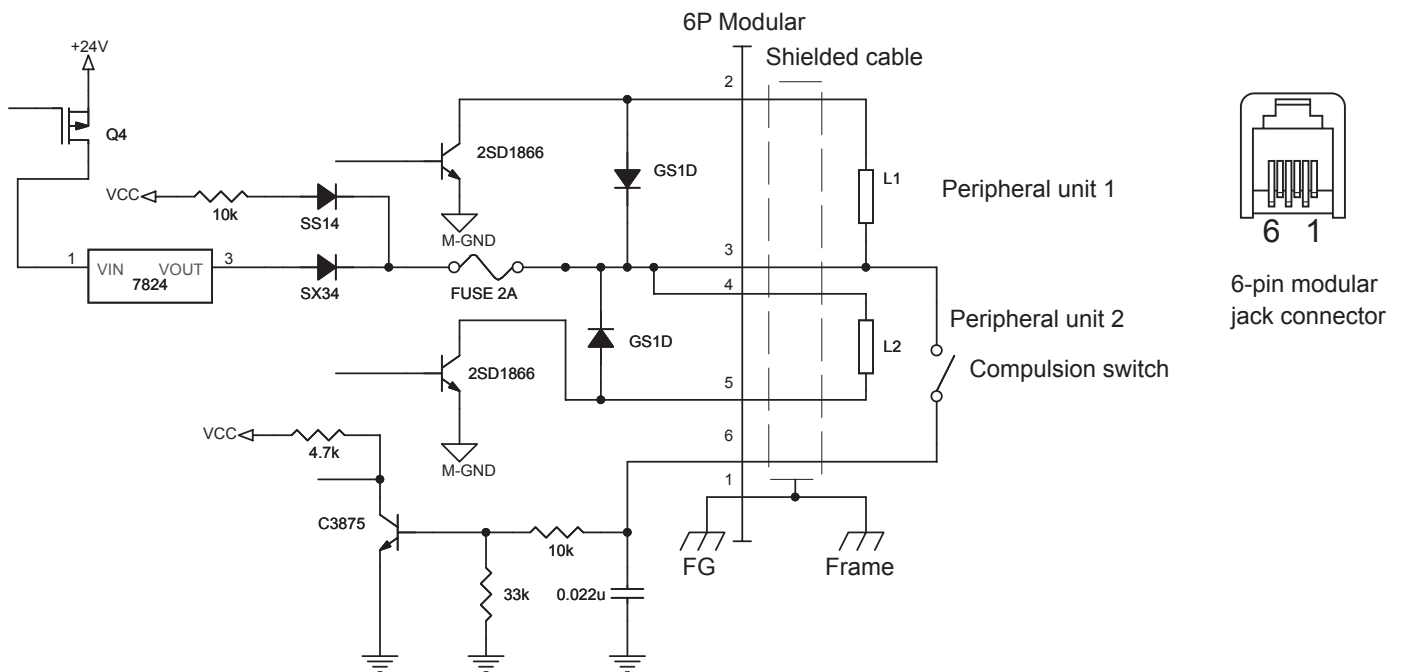

Reference
2SD 1866 Circuit Configuration

Drive Output: 24 V, Max. 1.0 A

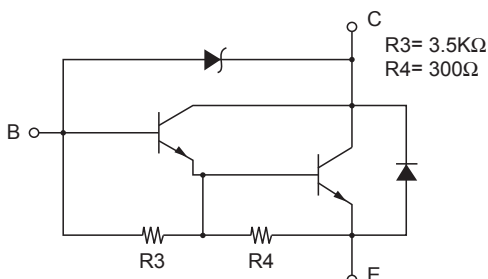

- Notes:**
1. Peripheral units 1 and 2 cannot be driven simultaneously. To drive them continuously, set the duty cycle ratio to 20% or less (excluding an externally connected buzzer).
 2. The following external buzzer unit is available as an option.
External buzzer model: BU01-24-A
 3. Never use the external buzzer command if you connect a device (such as a cash drawer) other than an external buzzer. It could damage the connected device and the printer circuit. Refer to the separate Programmer's Manual for details on commands.
 4. The status of the compulsion switch can be known from the status command. Refer to the separate Programmer's Manual for details.
 5. Minimum resistance for coils L1 and L2 is 24.
 6. Absolute maximum ratings for diodes D1 and D2 ($T_a = 25^\circ\text{C}$) are:
Average Rectified Current $I_o = 1\text{ A}$
 7. Absolute maximum rating for transistors TR1 and TR2 ($T_a = 25^\circ\text{C}$) are:
Collector current $I_c = 2.0\text{ A}$
 8. When the printer enters the print ready mode, Q4 in the drive circuit is off. Therefore, the voltage supplied to peripheral devices is the VCC voltage (approximately 3.3 V).

10. Specifications

10-1. General Specifications

- | | |
|-----------------------|--|
| (1) Printing method | Direct line thermal printing |
| (2) Print speed | Max. 1200 dots/sec. (150 mm/sec.) |
| (3) Dot density | Standard 8 dots/mm (203 dpi) |
| (4) Printing width | Max. 72 mm |
| (5) Roll paper | Refer to chapter 5 for details on the recommended roll paper.
Paper width: 79.5 ± 0.5 mm
57.5 ± 0.5 mm when the paper roll holder is used)
Roll diameter: $\varnothing 83$ mm or less |
| (6) Overall dimension | 142 (W) \times 204 (D) \times 132 (H) mm |
| (7) Weight | 1.72 kg (without roll paper) |
| (8) Noise Approx. | 50 dB |

Note: The noise measurements listed above were obtained according to conditions established by this company. The noise measurements may vary depending on the type of paper used, type of printing and operating environment.

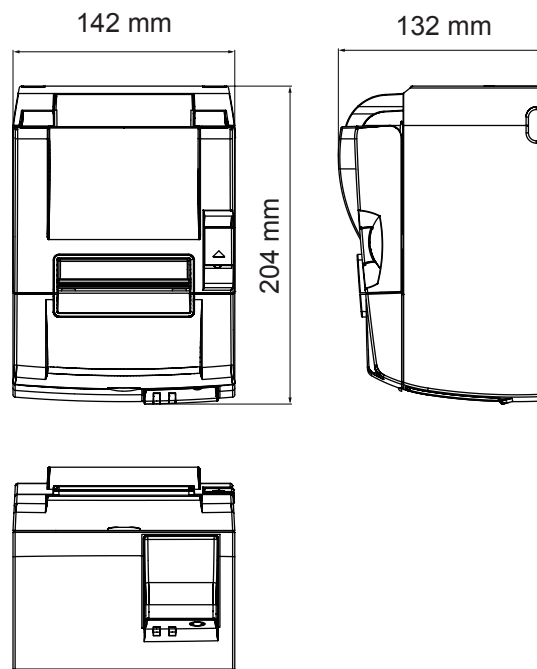

10-2. Auto Cutter Specifications

- (1) Cutting frequency Max. 20 cuts per minute
- (2) Thickness of paper 65~85 μm

10-3. Interface

- (1) Specifications USB 2.0 full speed
 Printer class and vendor class compatible
- (2) Connector Type B

Type B connector:

DUSB-BRA42-T11(D2)-FA (manufacturer: DDK) or equivalent

Pin No.	Signal name	Function
1	VBUS	USB Power pin (+5V DC)
2	D -	Serial Data -
3	D +	Serial Data +
4	GND	Signal ground

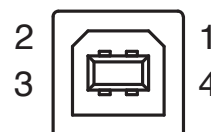

10-4. Electrical Characteristics

- (1) Input Voltage AC 100 - 240 V \pm 10%, 50/60 Hz
- (2) Current Consumption
 - System off mode: Approx. 0.05 W on average
 - Print ready mode: Approx. 0.76 W on average
 - ASCII character continuous printing: Approx. 34 W

10-5. Environmental Requirements

- (1) Operating
Temperature 5°C to 45°C
Humidity 10% to 90% RH (without condensation)

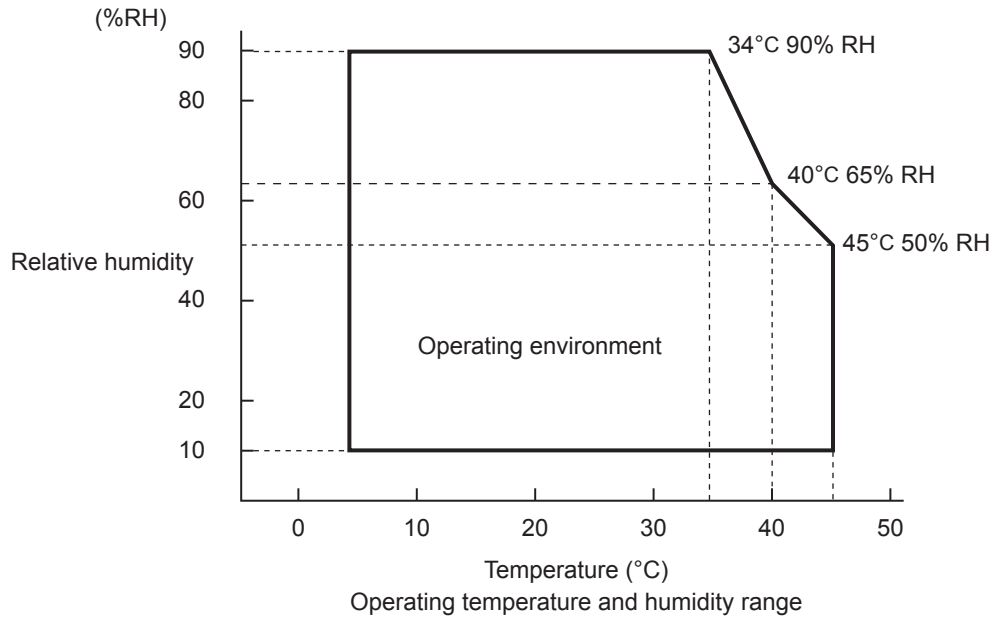

- (2) Transport/storage (except for paper)
Temperature -20°C to 60°C
Humidity 10% to 90% RH (without condensation)

10-6. Reliability

1) Life Mechanical: 20 million lines

The lives of the Head and Cutter may vary depending on the paper specifications.

They are shown in the table below:

<Conditions>

Average printing ratio: 12.5%

Average head resistance fluctuation: Max. $\pm 15\%$

Manufacturer	Product name	Head life		Cutter life	
		Number of Pulses	Distance	Paper width: 79.5mm (cuttings)	Paper width: 57.5mm (cuttings)
Mitsubishi Paper Mills Limited	P220AG	100 million	100 Km	1 million	0.6 million
	HP220A	100 million	100 Km	1 million	0.6 million
	HP220AB-1	100 million	100 Km	1 million	0.6 million
	P220AGB	100 million	100 Km	1 million	0.6 million
Mitsubishi HiTec Paper Flensburg GmbH	F5041	100 million	100 Km	1 million	0.6 million
Oji Paper Co., Ltd.	PD150R	100 million	100 Km	1 million	0.6 million
	PD160R	100 million	100 Km	1 million	0.6 million
	PD450	100 million	100 Km	1 million	0.6 million
Nippon Paper Industries	TF50KS-E2D	100 million	100 Km	1 million	0.6 million
	TF60KS-E	100 million	100 Km	1 million	0.6 million
Kanzaki Specialty Papers Inc. (KSP)	P320RB	50 million	50 Km	1 million	0.6 million
	P320BB	50 million	50 Km	1 million	0.6 million
	P300/P310	100 million	100 Km	0.5 million	0.3 million

2) MCBF: 60 million lines

The Mean Cycle Between Failure (MCBF) is defined to be the overall failure cycle, which includes random or wear failures that occur until the printer reaches its mechanical life of 20 million lines.

* As the mechanical remains at 20 million lines, the MCBF of 60 million lines does not indicate its useful life.

* All the reliability values indicated above are based on the use of the recommended thermal paper. No reliability can be guaranteed for the use of non-recommended thermal paper.



**SPECIAL PRODUCTS DIVISION
STAR MICRONICS CO., LTD.**

536 Nanatsushinya, Shimizu-ku, Shizuoka,
424-0066 Japan
Tel: (int+81)-54-347-0112, Fax: (int+81)-54-347-0409

Please access the following URL
<http://www.star-m.jp/eng/dl/dl02.htm>
for the latest revision of the manual.

**OVERSEAS SUBSIDIARY COMPANIES
STAR MICRONICS AMERICA, INC.**

1150 King Georges Post Road, Edison, NJ 08837-3729 U.S.A.
Tel: (int+1)-732-623-5555, Fax: (int+1)-732-623-5590

STAR MICRONICS EUROPE LTD.

Star House, Peregrine Business Park, Gomm Road,
High Wycombe, Bucks, HP13 7DL, U.K.
Tel: (int+44)-1494-471111, Fax: (int+44)-1494-473333